

CNC Spindle Control Upgrade Kit

The *CNC Spindle Control Upgrade Kit* provides for full CNC spindle control on the HiTorque Mini Mill, the HiTorque Mini Lathe, the HiTorque Bench Lathe, and the SIEG SX3 milling machine.



There are two CNC Spindle Control Upgrade Kits.

- PN 4213 works with the 500 watt brushless DC drive in the HiTorque Mini Mill and the HiTorque Mini Lathe.
- PN 4645 works with the 1000 watt brushless DC drive in the HiTorque Bench Lathe and the SIEG SX3 Small Mill.

The CNC Spindle Control Upgrade Kit includes the following parts:

PN 4213 for 500 watt drives

- KJ-1/110V circuit board
- 28-pin DIP chip
- 24" cable and connectors

PN 4645 for 1000 watt drives

- KJ-2/110V circuit board
- 28-pin DIP chip
- 24" cable and connectors

Preliminary

Mark the chip from the kit before doing anything else. Put a dot of paint or fingernail polish on the top of the chip at the notched end.

Once you have removed the chip from the controller there is no way to tell the chips apart without this marking.

Chip Installation

Follow these steps to install the motor controller circuit board.

SX2 and SC2 Chip Location

Locate the chip to change and make a note of the orientation. There is a notch in one end. The notch end is toward the smaller chip on the daughter board.

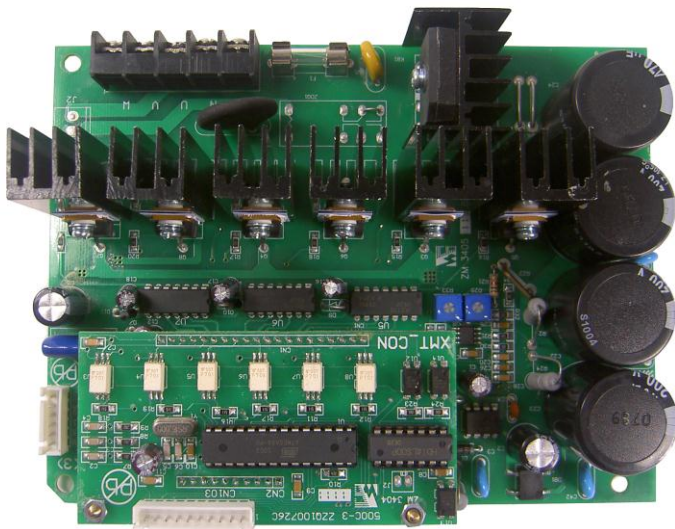

SX3 and SC4 Chip Location

Locate the chip to change and make a note of the orientation. There is a notch in one end. The notch end is toward the smaller chip on the daughter board.

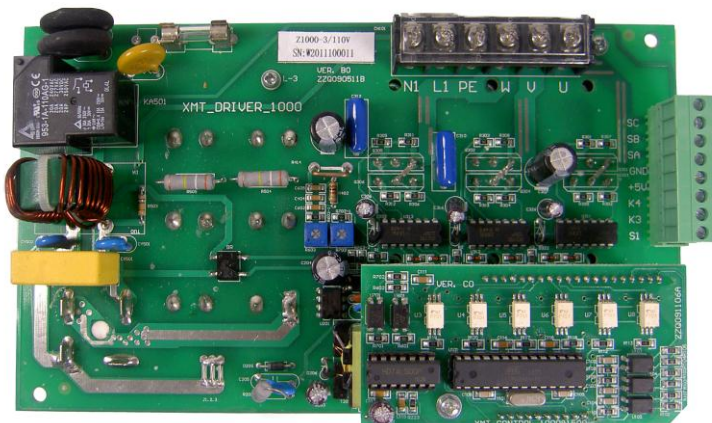

Using a small screwdriver, remove the chip from the socket.

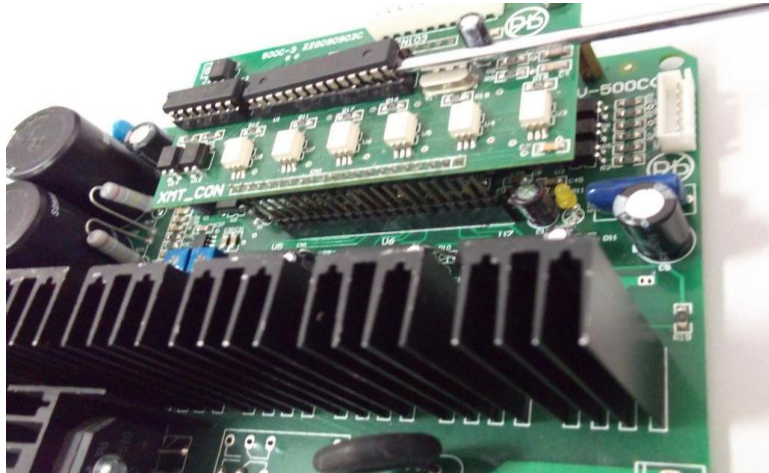

Respecting the orientation, insert the new chip into the socket. Take care not to bend any of the pins.

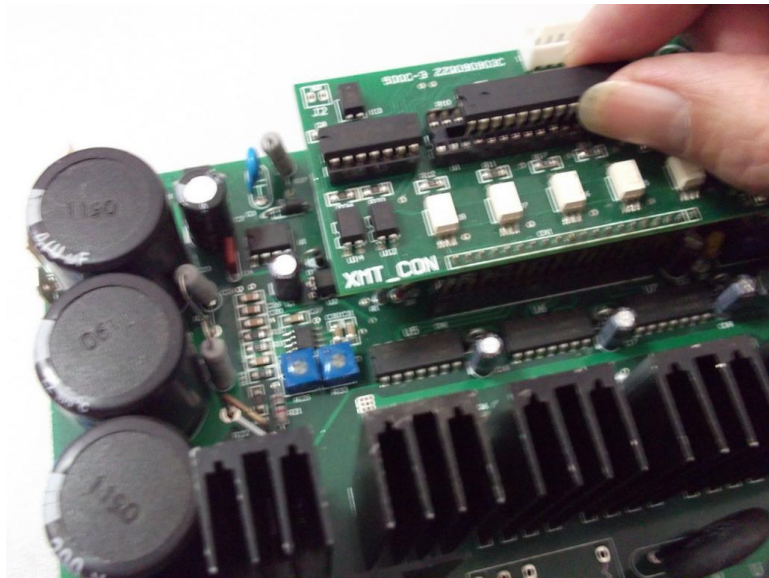

PCB Installation

Unplug the power cord from the receptacle.

Find an appropriate location to mount the circuit board within the cable length from the appropriately sized connector on the motor control circuit board.

Mount the circuit board using at least two of the four mounting holes.

Connect the new circuit board to the motor controller circuit board. The plug furnished will replace plug and cable from the potentiometer.

Make the appropriate connections to the green connector on the new circuit board. Start by adding the connection in the wiring diagram below. This is the simplest way to connect the CNC Spindle Control Upgrade Kit and have it operate. This will ensure that new parts are installed and working correctly.

The AC1 and AC2 terminals should connect to 120VAC 50 or 60 Hz. You can connect these to the L and N terminals on the controller board.

Connect a jumper from the GND terminal to the START/STOP terminal on the green connector. Connect a jumper from the +5V terminal to the AVI terminal. [Simplest Connections diagram only here]

There are several wiring diagrams included in this document. After running the motor with the Simplest Connections, you can proceed to make connections to your breakout board.

Speed Adjustment

You can adjust the motor speed at the maximum voltage by turning potentiometer W1. Look for the small rectangle with the adjustment screw adjacent to the green connector.

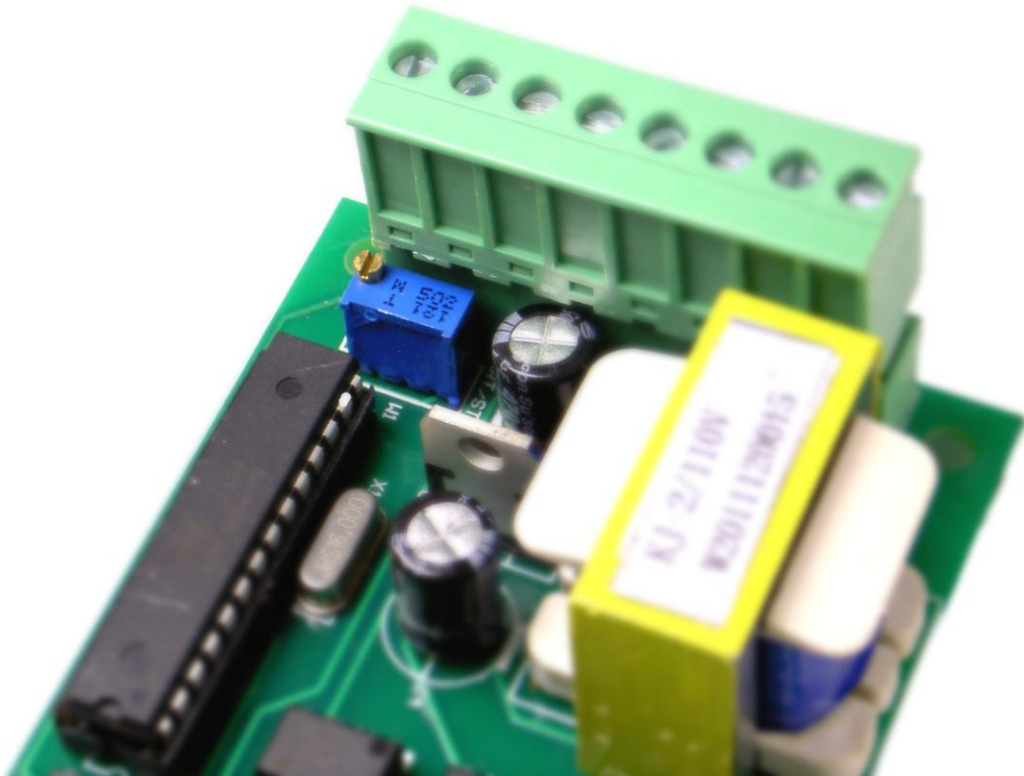

Wiring Diagram

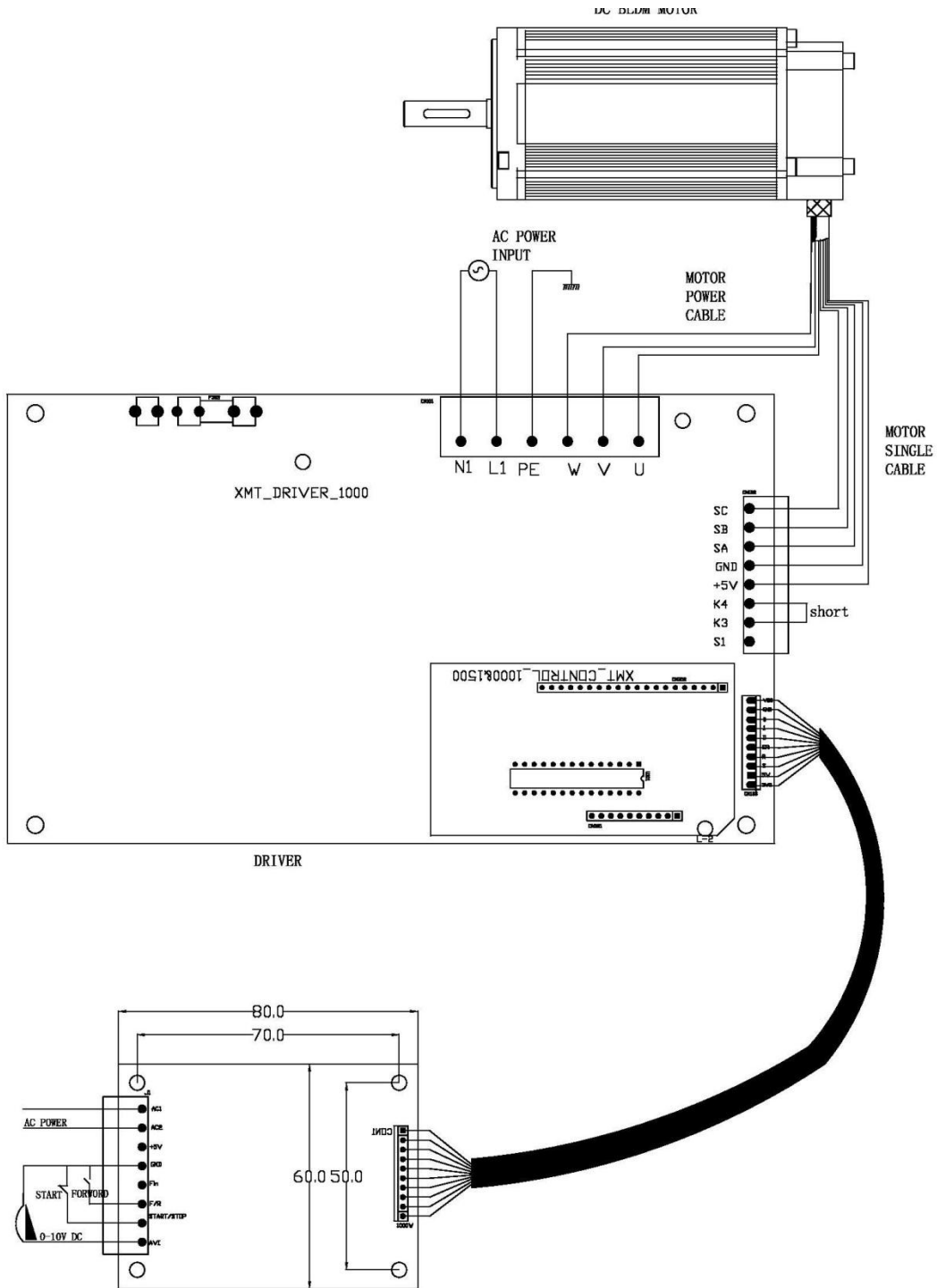

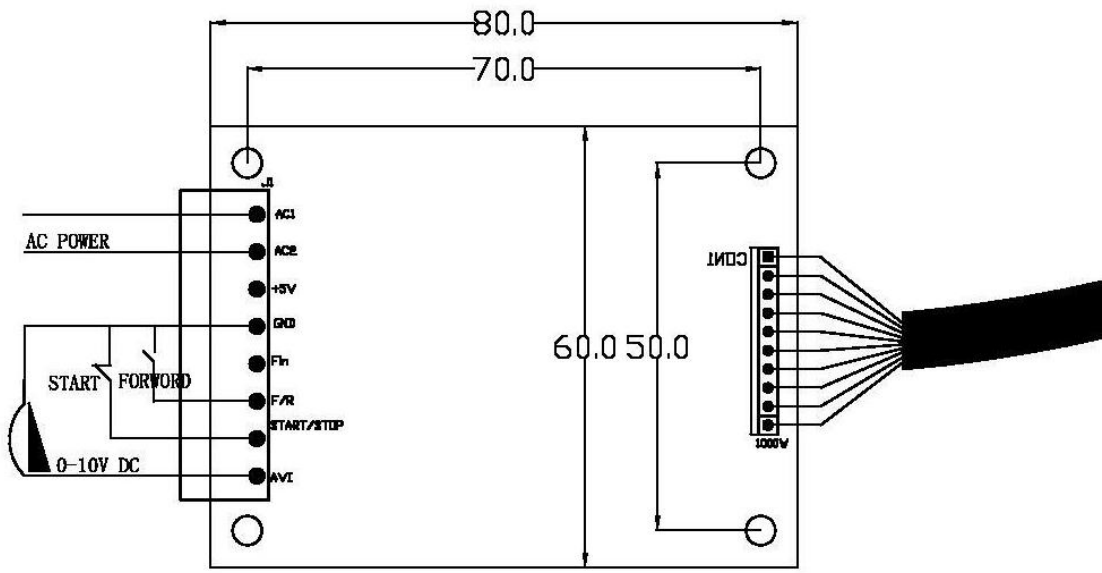

Simplest Connections

120VAC from terminals L & N
on motor controller board

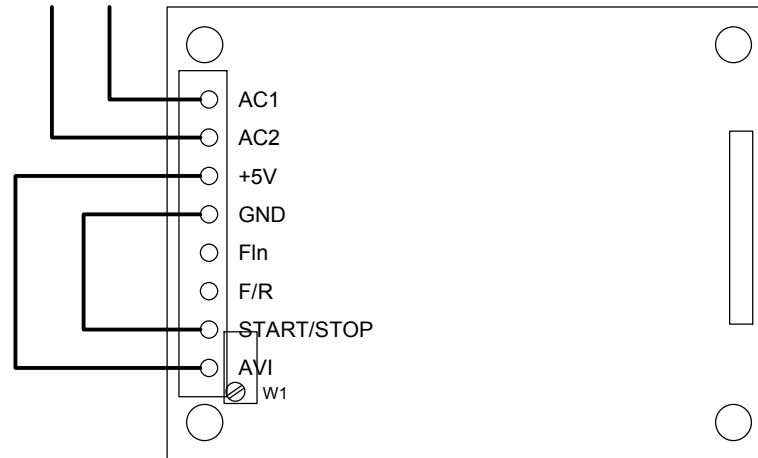

LittleMachineShop.com

© 2012 LittleMachineShop.com. All rights reserved.

Simplest Connections

Revision 0

4213

Sheet 2 of 4

Gecko G540

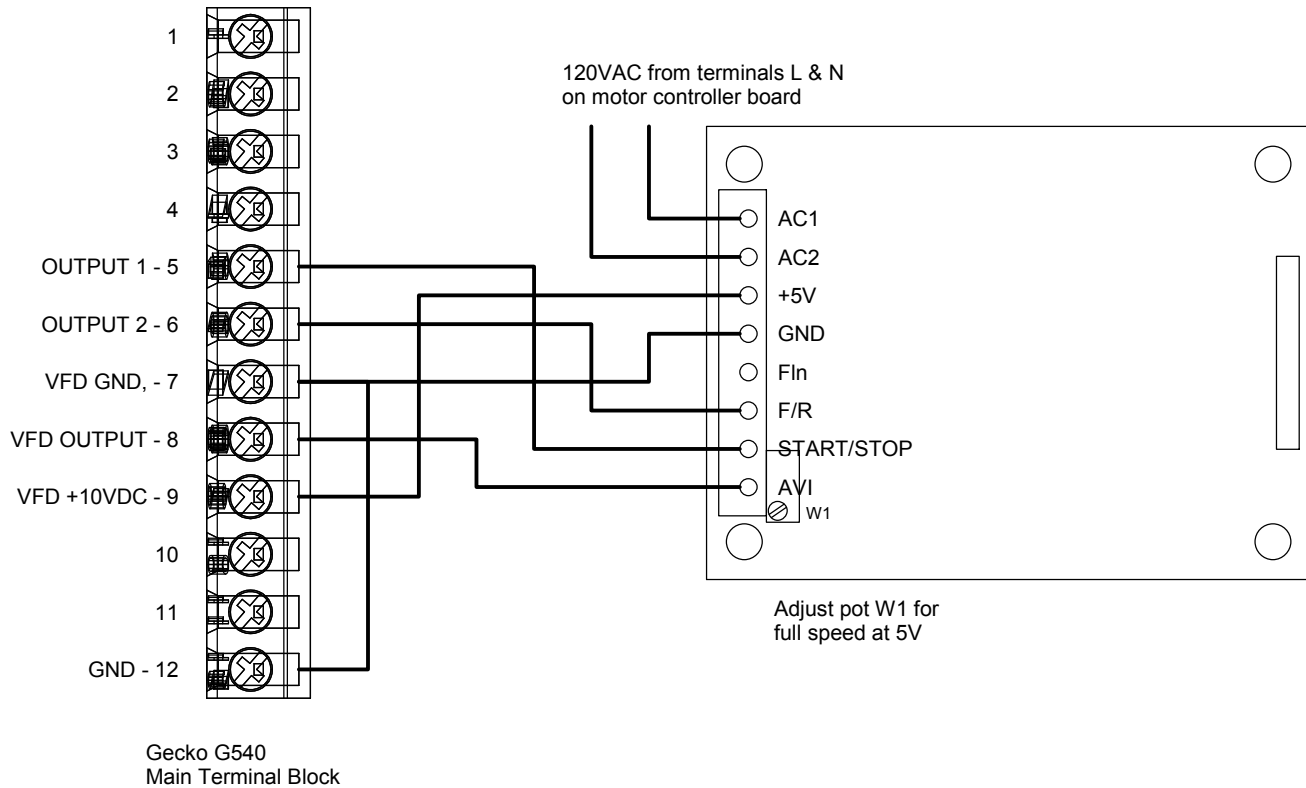

LittleMachineShop.com

© 2012 LittleMachineShop.com. All rights reserved.

G540 Connections

Revision 0

4213

Sheet 3 of 4

CNC4PC C11G

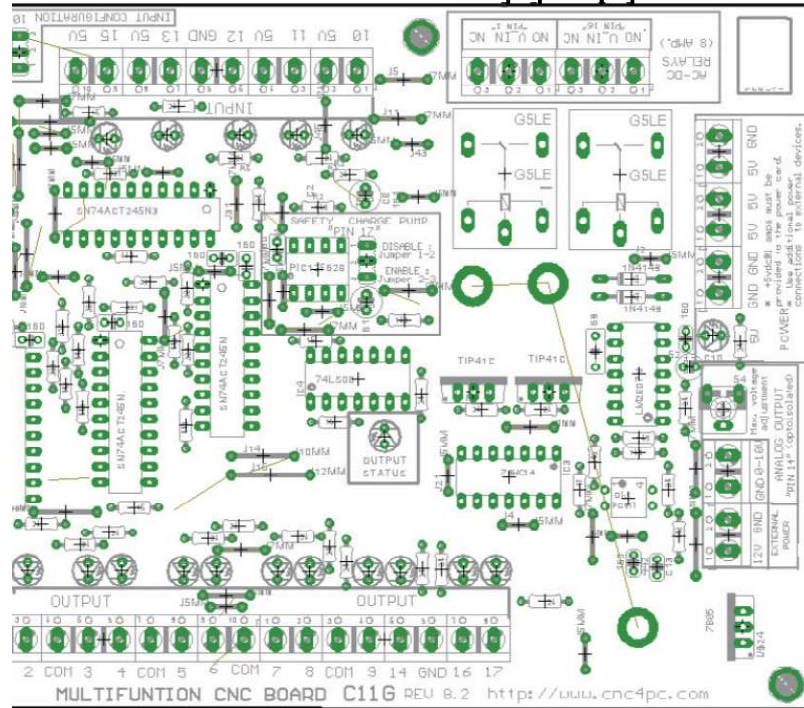

120VAC from terminals L & N
on motor controller board

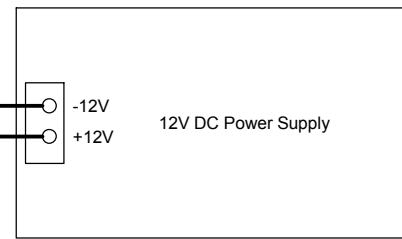
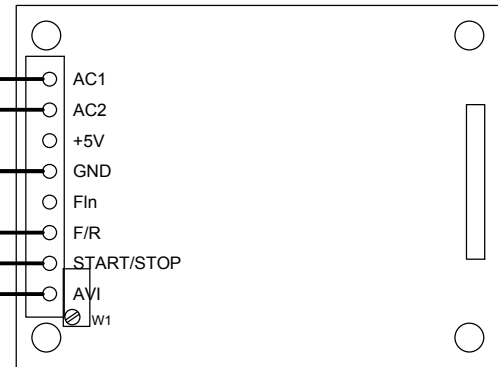

LittleMachineShop.com

© 2013 LittleMachineShop.com. All rights reserved.

C11G Connections